

DoD Ergonomics Working Group NEWS



Issue 63, April 2007

www.ergoworkinggroup.org

Showcasing Success: Ergonomic Interventions at the Fleet Readiness Center East

About FRC East

Located at Cherry Point, North Carolina, FRC East is one of six fleet readiness centers operated by the U.S. Navy. During its more than six decades of operation, FRC East has provided maintenance, engineering and logistics support on a variety of aircraft, engines and components for all branches of the U.S. Armed Forces.

From its beginnings in 1943, FRC East has grown to become eastern North Carolina's largest industrial employer. The Center employs about 4,000 civilian, military and contractor personnel, who work in a wide variety of skilled technical and professional positions.

Successful ergonomic interventions have played a significant part in making the lives of these 4,000 workers safe and healthy.

Why the Interventions Work

Four key reasons for FRC East's success are:

- Ergonomic and financial support of the commanding and executive officers.
- Ergonomic studies are performed to determine the type of interventions needed.
- Ergonomic equipment is purchased based on team decisions.
- All ergonomic decisions are approved by both the employees and management.

Just a few examples of FRC East's successes are on the following pages, featuring these equipment interventions: motorized tilt table, scissor lift, and Lazy Susan table.

More Information

Contact FRC East's ergonomist, Rich Borcicky, at 252-464-5165 to discuss the many successful interventions in place at Cherry Point.

Motorized Tilt Table

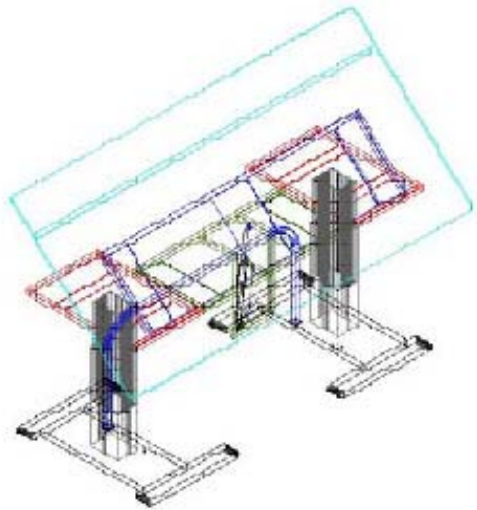

Ergonomic Issues:

- Posture
- Repetition
- Compression
- Duration

Design:

- Tilt-top, height adjustable table
- 96" x 48"
- 750 lbs lift
- 20" stroke

From Design to Reality



**Pneumatic manifold with three couplings.
No falling over airlines.**

Scissor Lift

Ergonomic Issues: Posture, Repetition, Compression, Duration?

Design:

From this



Mobile handling scissor lift table with battery lift operation that enables the operator to place the load at a convenient working height.



to this



in just 3 seconds!

Lazy Susan Table

Ergonomic Issues: Posture, Repetition, Compression, Duration?

Working in circles can take an ergonomic toll on the body in the Rotor Head Shop.

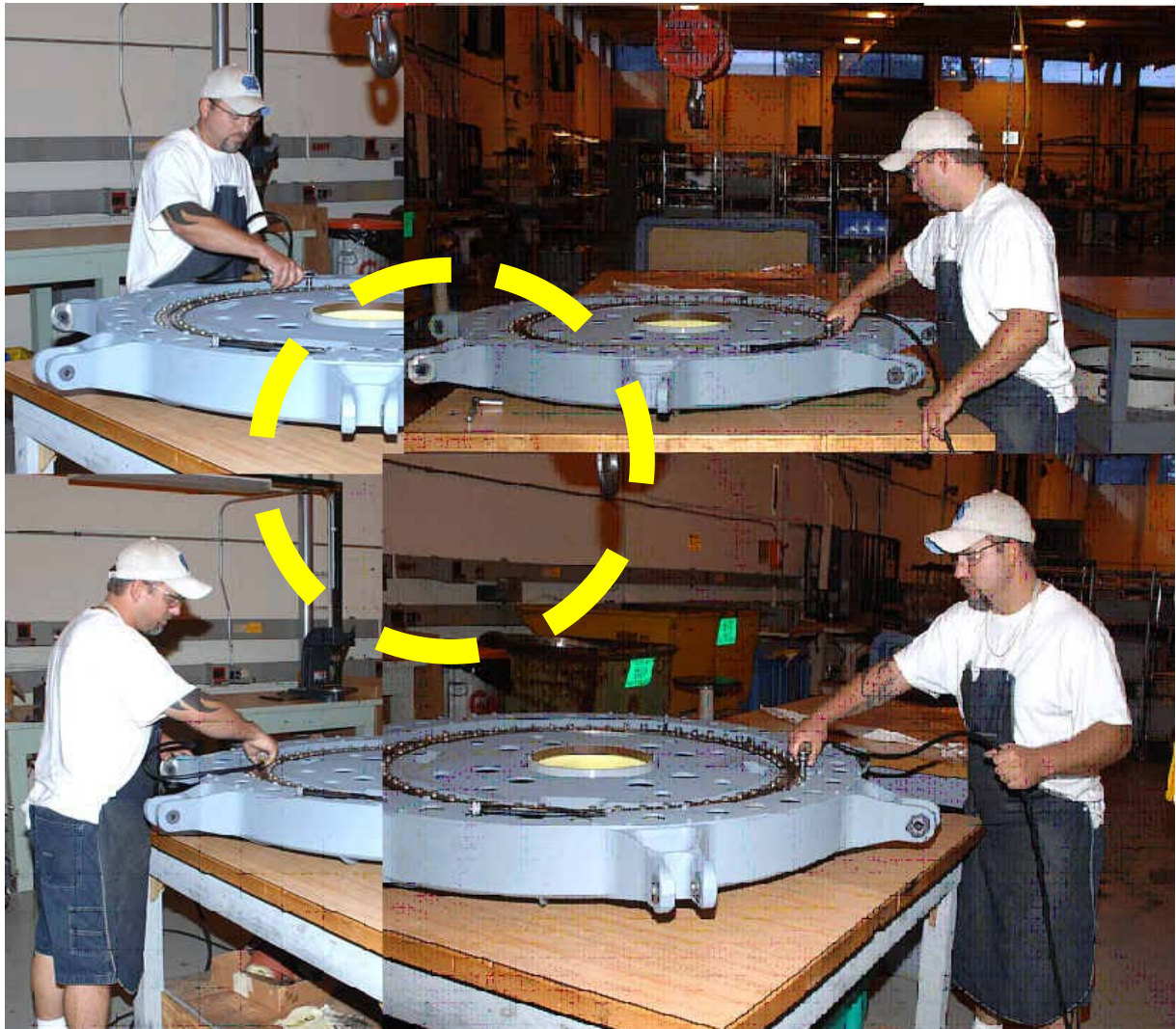

Design: Adjustable table that works like a Lazy Susan and holds up to 700 lbs.

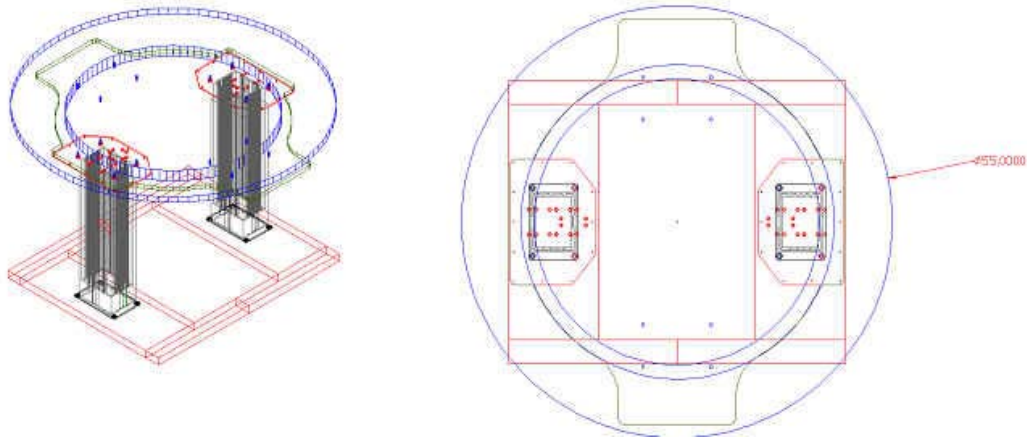

The new design in action, with the addition of an ergonomic stool!

